

SEE DET. "A"

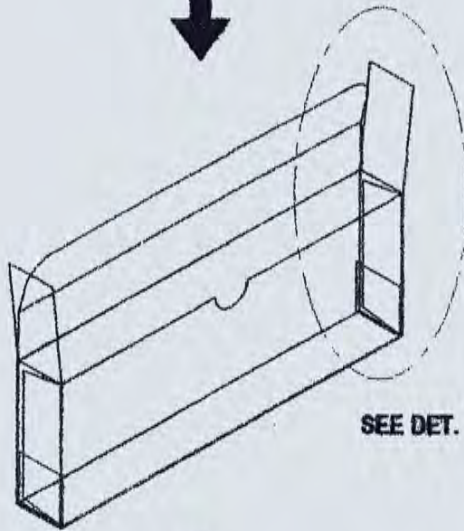

SEE DET. "B"

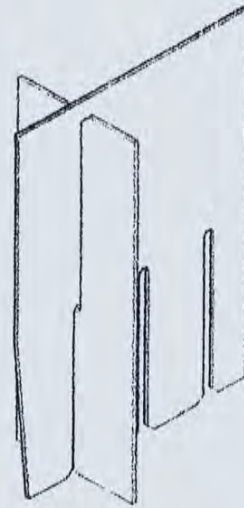
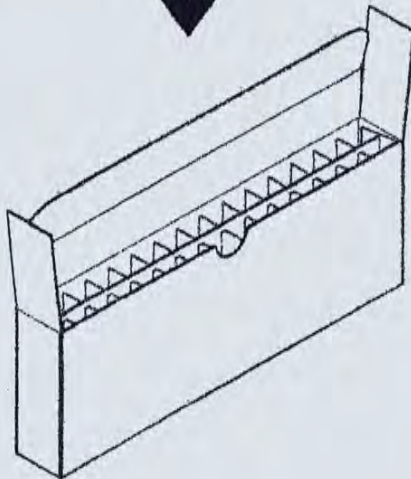

DETAIL "A"

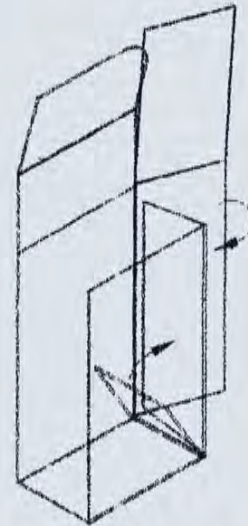

DETAIL "B"

|                     |  |       |               |   |            |         |
|---------------------|--|-------|---------------|---|------------|---------|
| DRAWN               | <i>J.C. Caranilla</i><br>J.C. CARANILLA  | Date: | MAR. 08, 2017 |  Republic Of The Philippines<br>Department of National Defense<br><b>GOVERNMENT ARSENAL</b><br>Camp General Antonio Luna<br>Lamac, Limay, Bataan | Scale:     | NTS     |
| DESIGNED            |  | Date: |               |   | Dimension: | MM      |
| CHECKED             | <i>ENGR. S.K.O. Paguio</i><br>ENGR. S.K.O. PAGUIO                                    | Date: |               | TITLE:<br><b>ASSEMBLY OF CARTON BOX</b><br>For GA 762100 / GA 762105 / GA 762300 /<br>GA 762400 / GA 762500 / GA 762505 / GA 762600   | Dwg. No.   | GCBA-17 |
| Recommend Approval: | <i>ENGR. Crisostomo M. Marcos</i><br>ENGR. CRISOSTOMO M. MARCOS<br>ACTING Supt. / ED | Date: |               |   | Sht.No.    | 1       |
| Approved by:        | <i>JONATHAN E. MARTIN</i><br>JONATHAN E. MARTIN<br>DIRECTOR                          | Date: |               |   | Of         | 1       |

| LTW        | MODIFICATION | DATE | REFERENCE | APPLY GEN TOLERANCE TO UNSPECIFIED DIMENSIONS |
|------------|--------------|------|-----------|---|
| 0 TO 6     |              |      |           | 0 TO 6  |
| 6 TO 30    |              |      |           | 6 TO 30                                       |
| 30 TO 100  |              |      |           | 30 TO 100                                     |
| 100 TO 315 |              |      |           | 100 TO 315                                    |
| 315 TO 500 |              |      |           | 315 TO 500                                    |

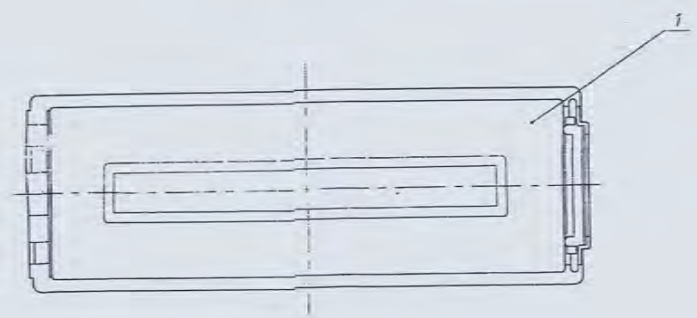
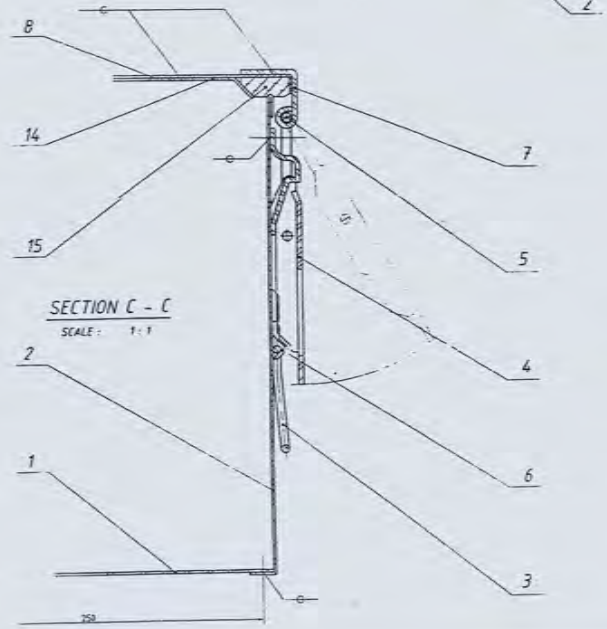
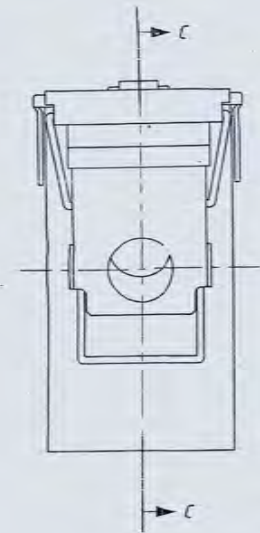
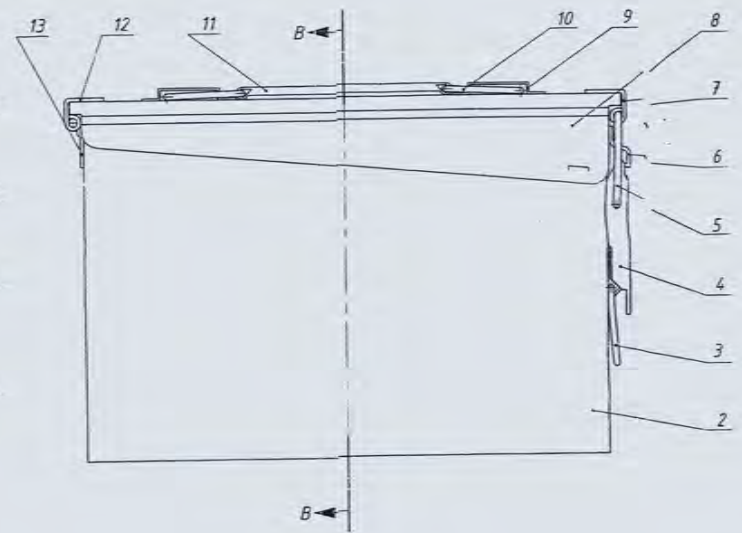
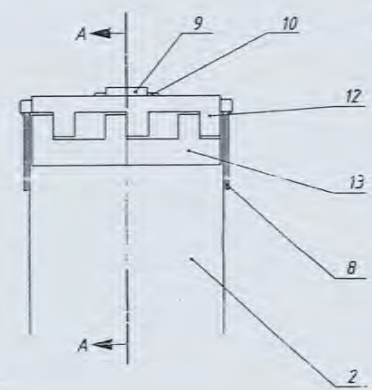
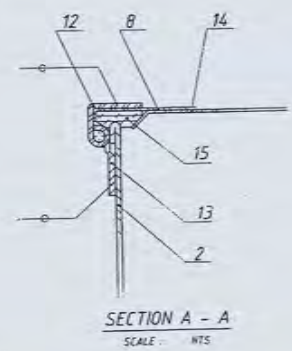
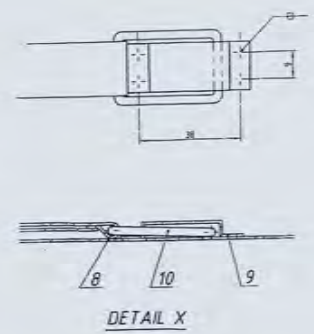
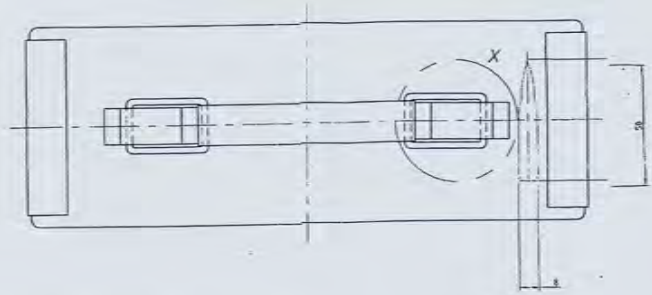
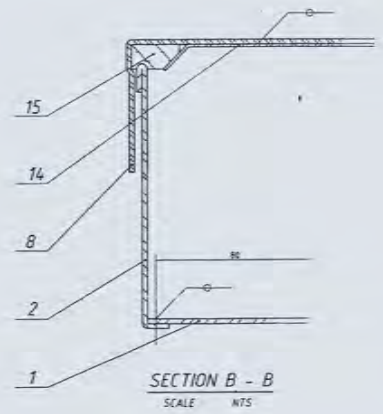

**GENERAL SPECIFICATION and ACCEPTANCE PROCEDURES**  
UNLESS OTHERWISE SPECIFIED IN THE DRAWINGS, PROVISIONS OF TECHNICAL BULLETIN No. 107, DATED AUG. 4, 1992, SHALL APPLY.

| QTY | DESCRIPTION           | PART NO | MATERIAL / HARDNESS   |
|-----|-----------------------|---------|-----------------------|
| 1   | RUBBER GASKET         | 15      | NEOPRENE OR HYPALON   |
| 1   | GASKET RETAINER PLATE | 14      | TIN FREE STEEL        |
| 1   | BODY HINGE            | 13      | TIN FREE STEEL        |
| 1   | COVER HINGE           | 10      | TIN FREE STEEL        |
| 1   | COVER HANDLE          | 7       | TIN FREE STEEL        |
| 3   | HANDLE HOLDER         | 10      | COLD DRAWN STEEL WIRE |
| 2   | COVER HANDLE CLIP     | 9       | TIN FREE STEEL        |
| 1   | TOP COVER PLATE       | 8       | TIN FREE STEEL        |
| 1   | LATCH HINGE RETAINER  | 7       | TIN FREE STEEL        |
| 1   | HASP                  | 6       | TIN FREE STEEL        |
| 1   | LATCH HOLDER          | 5       | COLD DRAWN STEEL WIRE |
| 1   | LATCH PLATE           | 4       | TIN FREE STEEL        |
| 1   | END HANDLE            | 3       | COLD DRAWN STEEL WIRE |
| 1   | BODY PLATE            | 2       | TIN FREE STEEL        |
| 1   | BOTTOM PLATE          | 1       | TIN FREE STEEL        |

|   |  |  |  |
|---|--|--|--|
| DRAWN: <i>[Signature]</i><br>DESIGNED: <i>[Signature]</i><br>CHECKED: Engr. ESPINOSA, C.E.<br>RECOMMENDING APPROV: Engr. ROMERO, C.E.<br>APPROVED BY: <i>[Signature]</i><br>RAON ERBERTE C. YARONA, AFP | DATE: 01 AUG 93<br>DATE: 01 FEB 93<br>DATE: 03 OCT 93<br>DATE: | REPUBLIC OF THE PHILIPPINES<br>DEPARTMENT OF NATIONAL DEFENSE<br><b>GOVERNMENT ARSENAL</b><br>Camp General Antonio Luna<br>LAMPANG LIPAY, BATAAN | Scale: 1:1.25<br>Dimension: MM<br>Dwg. No: 1508.408<br>Sht. No: 1<br>OF 01 |
|---|--|--|--|

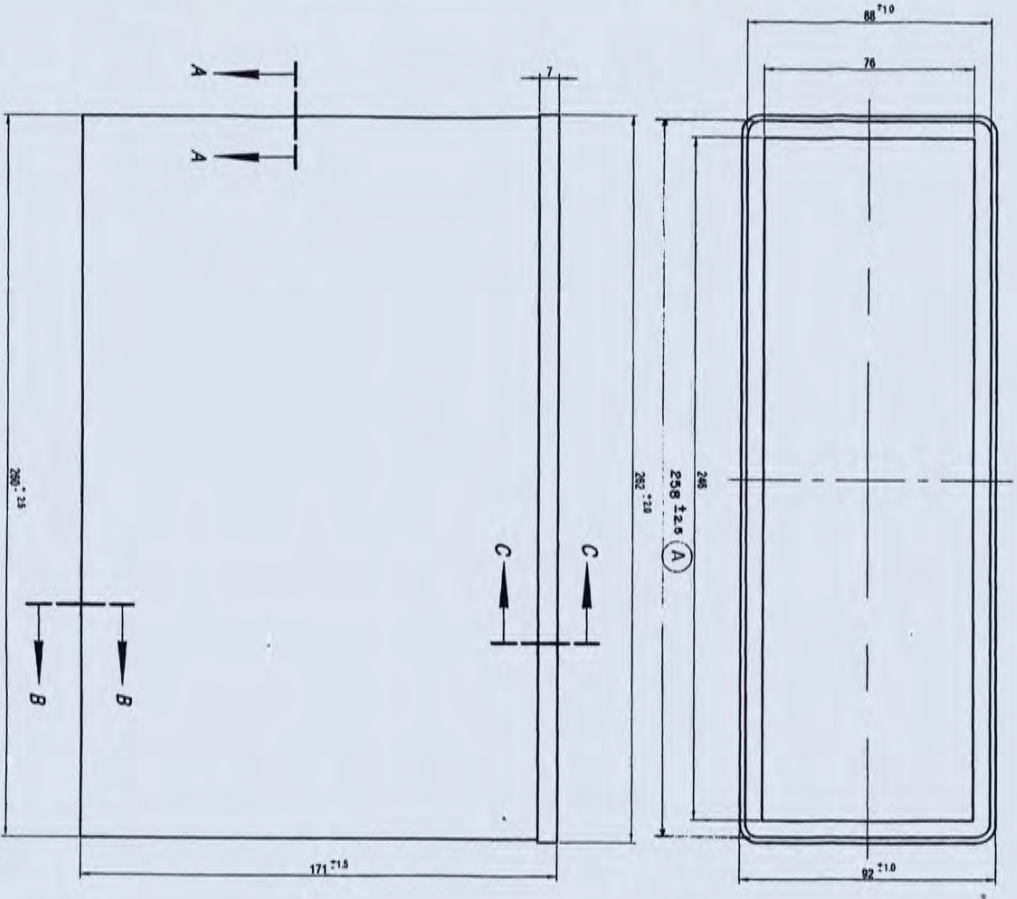

**2**  
BODY PLATE  
SCALE: 1:0.75

|     |   |                         |                  |                          |
|-----|---|-------------------------|------------------|--------------------------|
| LTR | A | 256 225                 | 8.4m (27' 6.75") | SEED OF 8.4m (27' 6.75") |
|     |   | MODIFICATION / ADDENDUM | DATE             | REF                      |

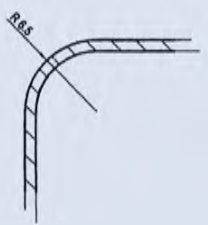

SECTION A-A  
SCALE: 1:3

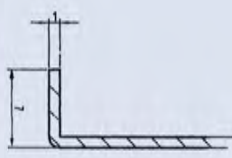

SECTION B-B  
SCALE: 1:3

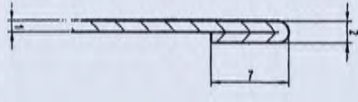

SECTION C-C  
SCALE: 1:3

**1**  
BOTTOM PLATE

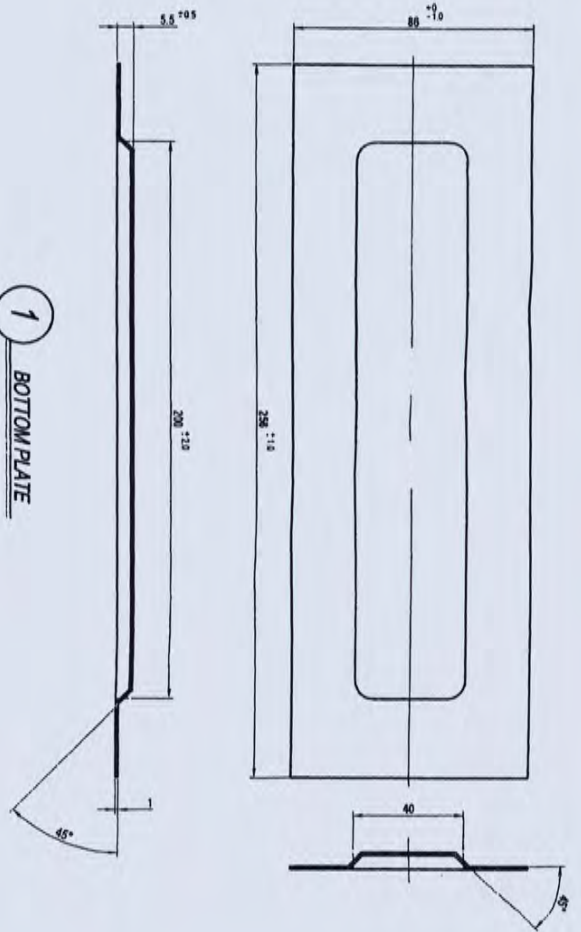

|  |                |                          |                |                           |            |
|--|----------------|--------------------------|----------------|---------------------------|------------|
| QTY  | 1              | DESCRIPTION              | 2              | MATERIAL                  | Scale:     |
| DRWING                                       | 1              | BOTTOM PLATE             | 1              | 7MM FIBRE STEEL 1.0 THICK | N.T.S      |
| DESIGNED                                     | 1              | B.S. JOSE                | 1              | 7MM FIBRE STEEL 1.0 THICK | Denotes:   |
| CHECKED                                      | 1              | Engr. M. ESPINOSA C.A.E. | 1              |                           | LM         |
| Recommended Approval:                        | Date: 12.6.06  |                          | Date: 02/13/11 |                           | Draw. No.: |
| ENGR. ROMEO C. FERRAN LIE                    | Date: 02/13/11 |                          | Date: 02/13/11 |                           | Scale:     |
| SPT. ENGR. ROMEO C. FERRAN LIE               | Date: 02/13/11 |                          | Date: 02/13/11 |                           | GBR 402-1  |
| Approved by: RADM. ESPERIDIO VARGONA AFP (R) | Date: 02/13/11 |                          | Date: 02/13/11 |                           | SKES: 2    |
| RADM. ESPERIDIO VARGONA AFP (R)              | Date: 02/13/11 |                          | Date: 02/13/11 |                           | 7          |
| DIRECTOR                                     | Date: 02/13/11 |                          | Date: 02/13/11 |                           |            |



Republic of the Philippines  
Department of National Defense  
Government Arsenal  
Camp General Antonio Luna  
Luzon, U.S.A.

METAL AMMUNITION BOX  
FOR 7.62MM

| LTP | MODIFICATION | DATE | REFERENCE | APPLY GEN. TOLERANCE TO UNSPECIFIED DIMENSIONS |
|-----|--------------|------|-----------|--|
|     |              |      |           | 0 TO 6   |
|     |              |      |           | 6 TO 30  |
|     |              |      |           | 30 TO 120                                      |
|     |              |      |           | 120 TO 315                                     |
|     |              |      |           | 315 TO 800                                     |
|     |              |      |           | ±0.3   |
|     |              |      |           | ±0.5   |
|     |              |      |           | ±0.8   |
|     |              |      |           | ±1.2   |
|     |              |      |           | ±2.0   |

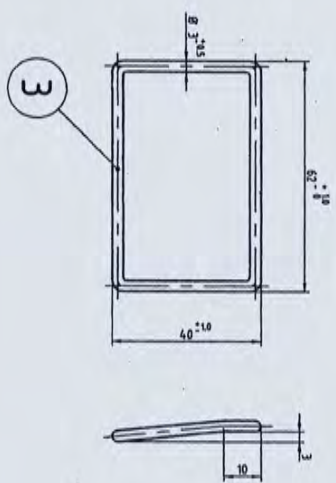
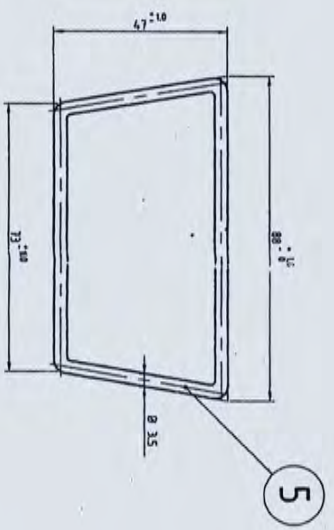
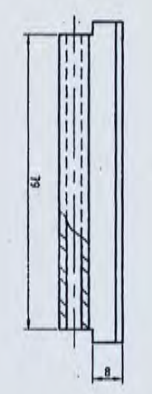
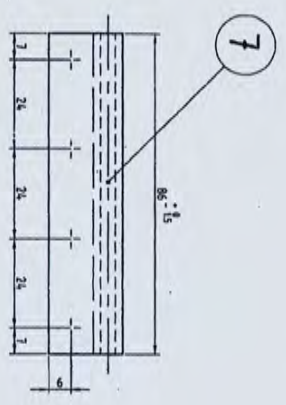
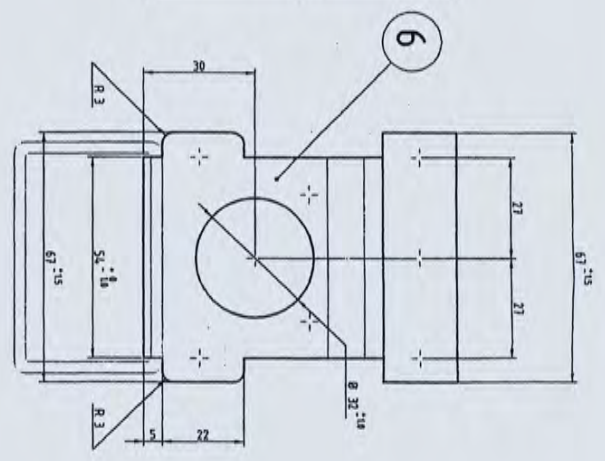
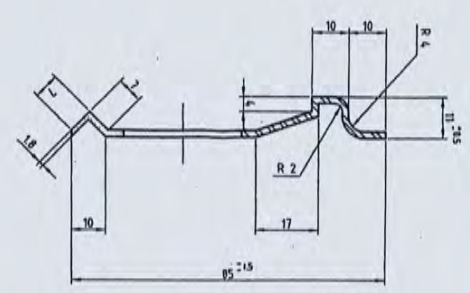
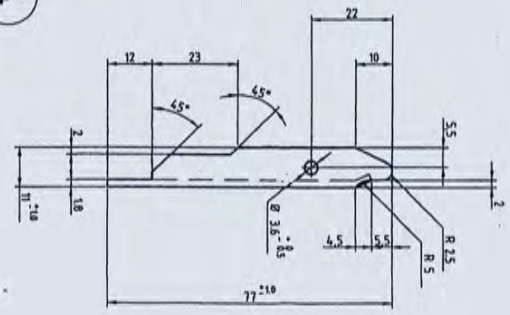
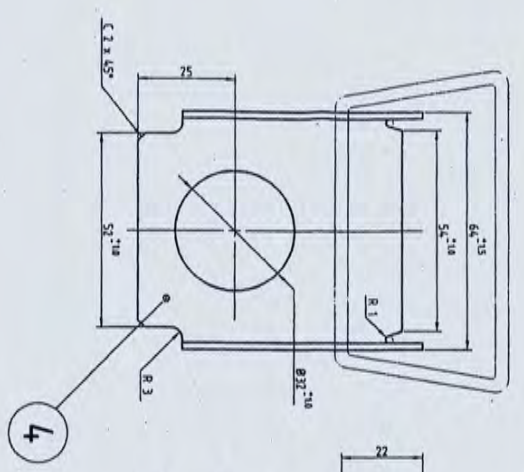

| NO   | DESCRIPTION          | QTY     | MATERIAL / HARDNESS   |
|--|----------------------|---------|-----------------------|
| 1  | LATCH HINGE RETAINER | 18 THK  | TIN FREE STEEL        |
| 1  | HASP                 | 1.8 THK | TIN FREE STEEL        |
| 1  | LATCH HOLDER         | Ø 3.5   | COLD DRAWN STEEL WIRE |
| 1  | LATCH PLATE          | 1.8 THK | TIN FREE STEEL        |
| 1  | END HANDLE           | Ø 3     | COLD DRAWN STEEL WIRE |
| D I S C I P T I O N  |                      |         |                       |
| PART NO  |                      |         |                       |
| REPUBLIC OF THE PHILIPPINES<br>DEPARTMENT OF NATIONAL DEFENSE<br>GOVERNMENT ARSENAL<br>Camp General Aniano Luna<br>LAMPALAY BATAAN |                      |         |                       |
| Scale: 1 : 1   |                      |         |                       |
| Dimension: MM  |                      |         |                       |
| Drawn No. GMB 403  |                      |         |                       |
| Sht. No. 3   |                      |         |                       |
| OF 7   |                      |         |                       |

Checked by: *[Signature]* Date: 27 Oct 03  
 Designed by: *[Signature]* Date: 27 Oct 03  
 Drawn by: *[Signature]* Date: 27 Oct 03  
 Recommended Approval: *[Signature]* Date: 27 Oct 03  
 Approved by: *[Signature]* Date: 27 Oct 03  
 PADM EMBERTO VASCON, AFP (Ret)  
 DIRECTOR

TITLE: METAL AMMUNITION BOX FOR 1.62 MM